

REINHOLD ENVIRONMENTAL Ltd.



## **2019 NO<sub>x</sub>-Combustion-CCR Round Table Presentation**

February 11 & 12, 2019, in Salt Lake City, Utah / Hosted by PacifiCorp

All presentations posted on this website are copyrighted by Reinhold Environmental, Ltd (RE). Any unauthorized downloading, attempts to modify or to incorporate into other presentations, link to other websites, or obtain copies for any other uses than the training of attendees to RE's Conferences is expressly prohibited, unless approved in writing by RE or the original presenter. RE does not assume any liability for the accuracy or contents of any materials contained in this library which were presented and/or created by persons who were not employees of RE.

# Mitigating Arsenic Poisoning of SCR Catalyst from Burning Gibson IB Coal

Jason Bookout (Southern Company) & Alex Jimenez (EPRI)  
2019 Reinhold PCUG  
February 11<sup>th</sup> 2019



# Introduction & project objectives



- Find a way for Plant Crist to burn Gibson fuel (High Arsenic/ Low Calcium) for an extended period of time and take advantage of favorable pricing.
- How does this affect the Catalyst Management Plan?
- What is the optimum limestone addition needed?
- What other species are affected by limestone addition? (Se, HCl, SO<sub>3</sub>)



# Plant Crist Unit 7



- Capacity: 520 MW
- Fuel: Bituminous IB Gibson fuel in early 2017.
- Process Flow diagram:
  - Opposed-wall fired
  - High dust SCR
  - Horizontal airheater
- Common FGD for U4, U5, U6, U7



Coal Grab Sample before limestone addition

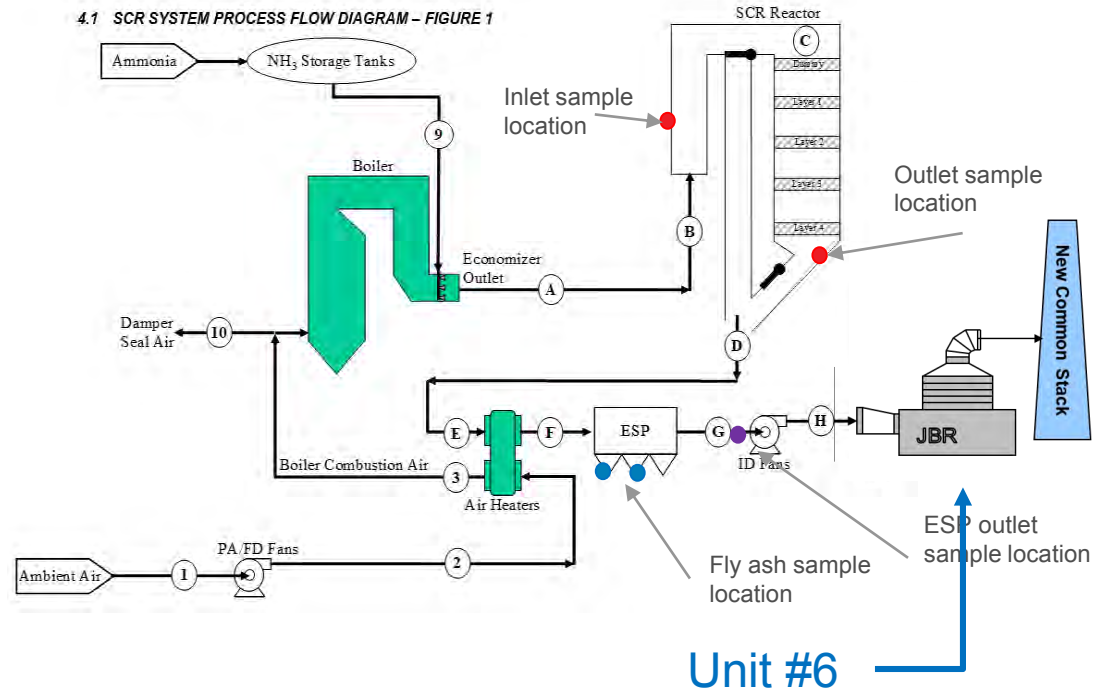

# Coal Comparisons

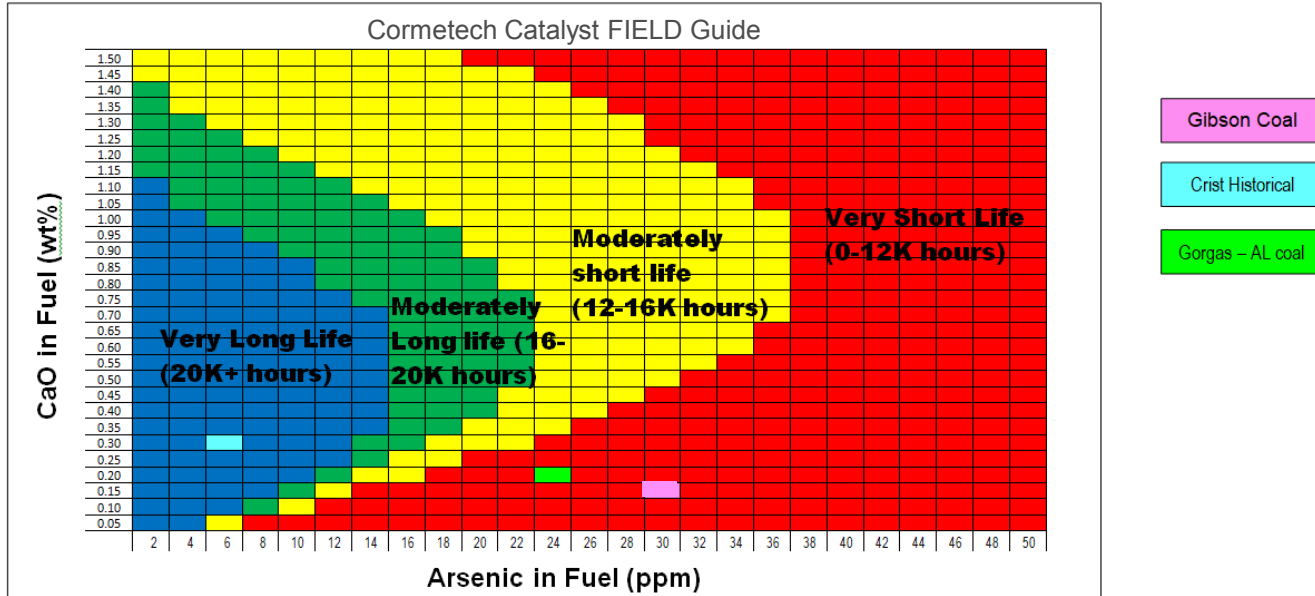

Fuel	Gibson Coal	Crist Historical	Gorgas (AL coal)
CaO in Ash (% dry)	1.66%	3.13%	1.78%
Ash% (dry)	8.01%	9.79%	12.46%
CaO in Fuel (% dry)	0.13%	0.31%	0.22%
As in fuel (ppmw, dry)	29.69	4.53	23.97
CaO/As Ratio ( $\times 10^5$ )	4.5	67.6	9.3
Deactivation rate @ 16k hrs.	0.35	0.65	0.485

# Limestone Reactions:

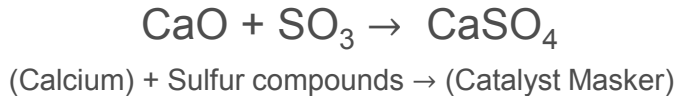
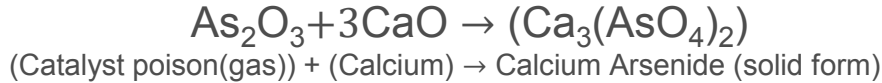
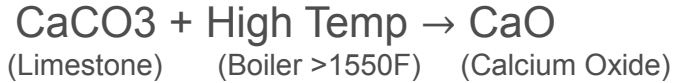

## Poisoning:

Deactivation of active catalyst sites by chemical attack

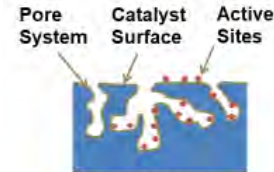

i.e. Arsenic,  
Phosphorus,

Not enough calcium

## Masking:

Macroscopic blockage of catalyst surface by dense second-phase coating

Dense Second-phase  
Coating

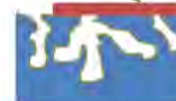

i.e. Calcium,  
Magnesium

Too much calcium

# Deactivation Rates- Predicted



- Historical deactivation rate (IB)  
= 0.65 @ 16k hrs

- Predicted deactivation rate (Gibson)  
= 0.35 @ 16k hrs

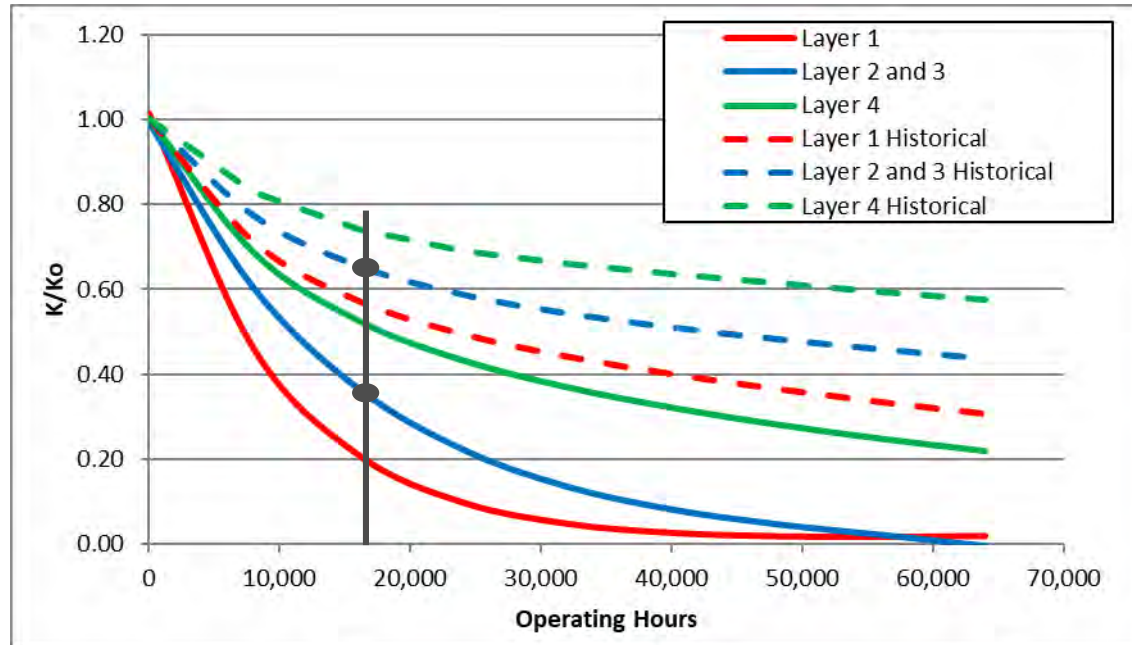

# Deactivation Rates- Actual



- Actual deactivation rate. (Gibson)  
~ 0.15 @ 16k hrs (top layer)

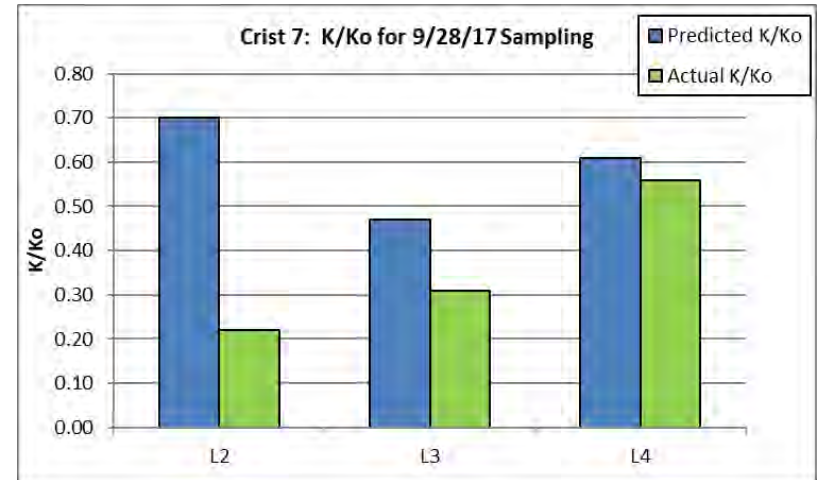
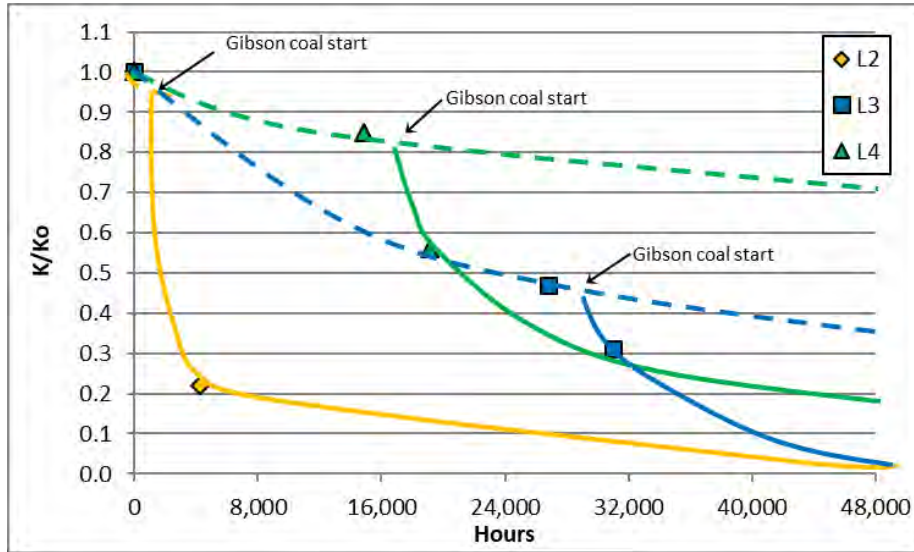

# Catalyst Management Plan @ Actual Deactivation

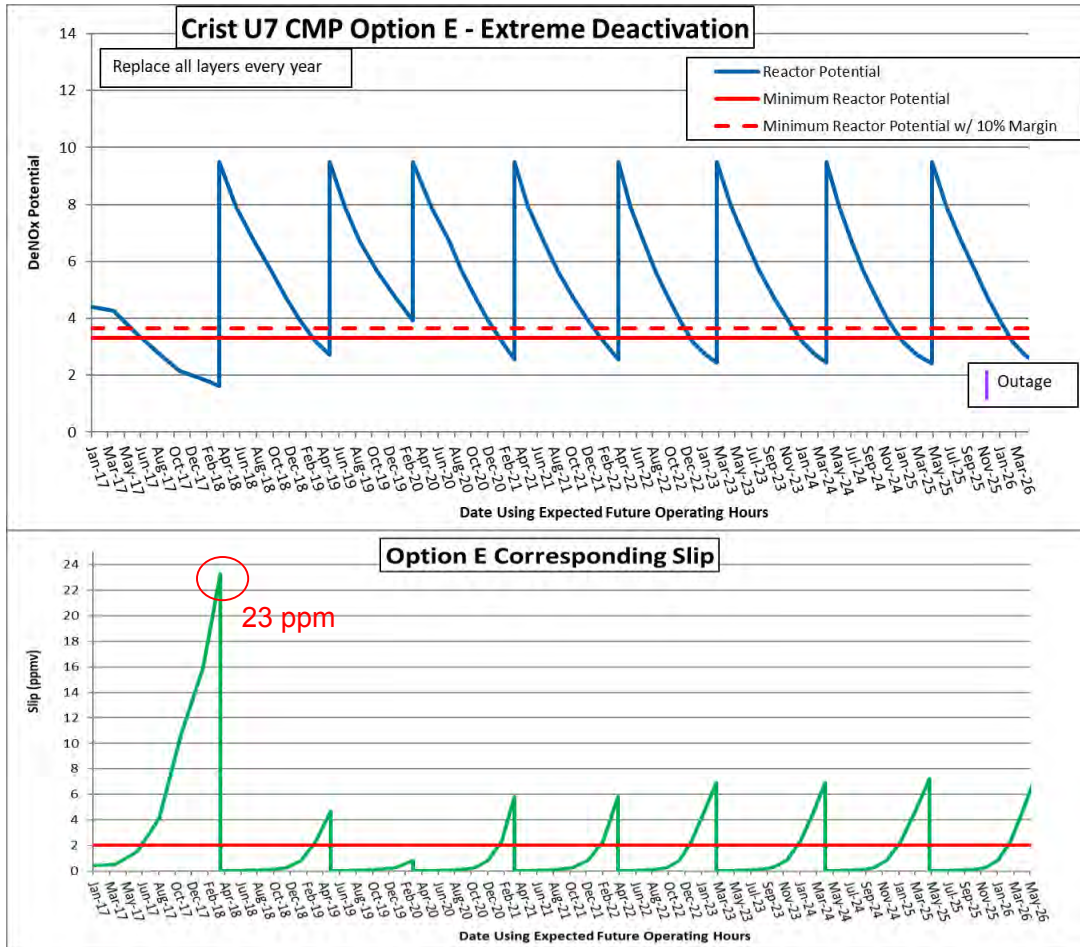

100% Gibson Coal No limestone addition-  
 Deactivation rate = 0.15 @  
 16k operating hours (Top layer).

All 4 layers of catalyst need to be replaced yearly!!!

# Severe ABS fouling in the horizontal AH:



- Severe operating conditions seen at Plant Crist during the end of 2017. The Plant came offline 9 times for air heater washes during a 7 month period.
- HLI upstream of AH began at the end of September 2017.
- NH3 slip testing indicated a slip of ~ 12.5 ppm

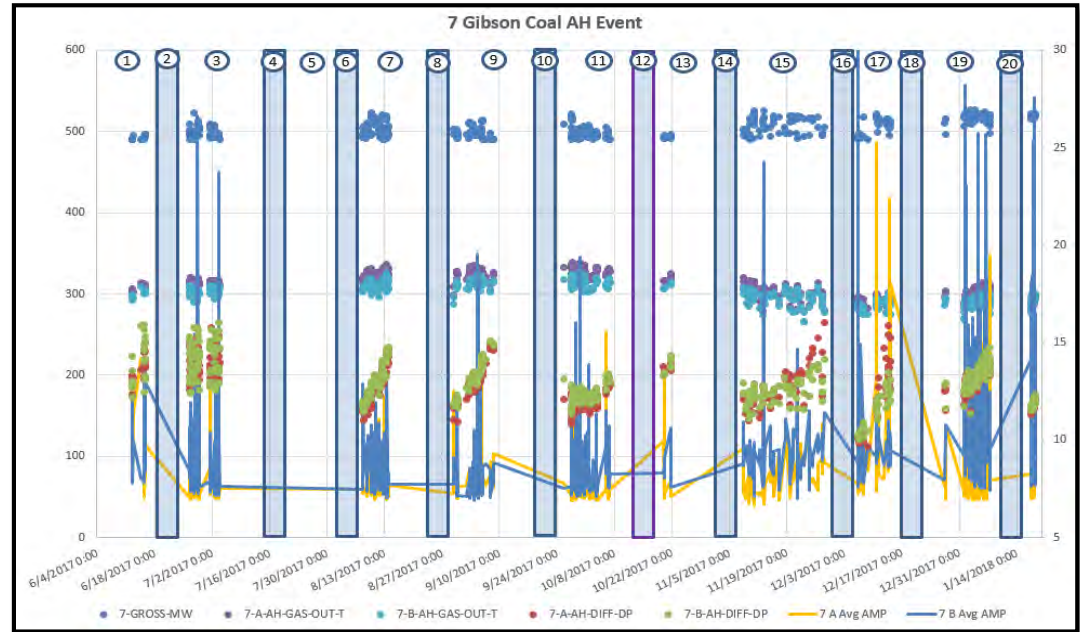

June 2017- Jan 2018

# Crist 7- Limestone Mitigation- Validation Testing (2 rounds- Spring/Summer 18)

## Spring 18:

Rushed test needed to be completed before upcoming outage.  
Fine limestone powder pneumatically conveyed directly into coal burner piping.  
Less than 2 weeks of available test time.

## Summer 18:

Re-test performed to verify initial test results.  
New conveying method with larger limestone added to coal belt.  
Additional species evaluated- SO<sub>3</sub>, HCl, Se, Hg.  
3 full weeks of test time available.



Original test plan 2 weeks: Reduced to 6 days.

# Test Plan- Spring 18

## Crist 7 Limestone into Boiler feed pipes

Rev 10- 2/2/18		UNIT OPERATIONS										Testing					
Week	Date	Day	Test Condition	Target(s)	Load (MW)	Limestone addition		Gas Measurements						Solids Samples			
						Added to coal belt		Pre-SCR			Post-SCR			Unit 7			
						Flow (lb/hr)	Flowrate (%)	Method 29 Metals (As)	SO3	Trap (As)	Method 29 Metals (As)	SO3/ NH3 slip	Trap (As)	Coal Analysis	*ESP Ash (CaO, Cl, SO3 concentrations)		
Evaluation of the effectiveness of limestone addition to the coal in order to decrease the concentration of gaseous arsenic going into the SCR.																	
1	Tuesday, January 30, 2018	1 - morning 1- afternoon	full load baseline	As <sub>2</sub> O <sub>3</sub> CaO	Low Full	0 0	0	2 runs 2 runs	Low (1) Full (1)	2 runs 2 runs	1 run 1 run		1 run	1 per day	Baseline sample		
	Wednesday, January 31, 2018	2 - morning 2- afternoon	full load at 2 injection rates	"	Full Full	2,600 3,500	0.50% 0.60%	2 runs 2 runs	1- up duct 1- Fgas in	1 run 1 run	1 run	1-fgas out	1 run	1 per day	1 sample @ each flowrate		
	Thursday, February 1, 2018	3 - morning 3-afternoon	Full load & low load-2 runs	"	Full/Low	2700/ 3,500	0.5-0.75%	2 runs 2 runs	1 run no NH3	2 runs				1 per day	1 sample @ each flowrate		
	Friday, February 2, 2018	4 - morning 4-afternoon	full load at 2 injection rates NH3 slip & SO3- no NH3 injection	"	Full Full	4,400 5,700	0.75% 1.30%	2 runs 2 runs	Rotary feeder Modification				NH3 slip test 12.58 ppm		1 per day	1 sample @ each flowrate	
	Saturday, February 3, 2018	5 - morning 5-afternoon	full load at 2 injection rates	"	Full	TBD TBD	TBD	2 runs 2 runs		1 run 1 run				1 per day	1 sample @ each flowrate		
	Sunday, February 4, 2018	6 - morning 6- afternoon	low load at 2 injection rates	"	Full Low	2,700 3,500	0.75% 1.30%	2 runs 2 runs		1 run 1 run				1 per day	1 sample @ each flowrate		
	2	Monday, February 5, 2018															
Tuesday, February 6, 2018																	
Wednesday, February 7, 2018																	
Thursday, February 8, 2018																	
Friday, February 9, 2018																	
Saturday, February 10, 2018																	

Test runs performed at full and low load conditions

After baseline testing, flowrates and concentrations varied from 0.3%-1.5%

- Method 29- (Gaseous arsenic + Calcium concentration)
- Ohio Lumex experimental Arsenic trap. (Gaseous arsenic)
- Daily Coal & precipitator ash analysis performed on Gibson fuel for trace elemental analysis.
- NH3 slip test performed at SCR outlet @ full load.



# Arsenic Control Through Limestone Addition:

Elevation change max:      Approx. 25 ft (need to verify)

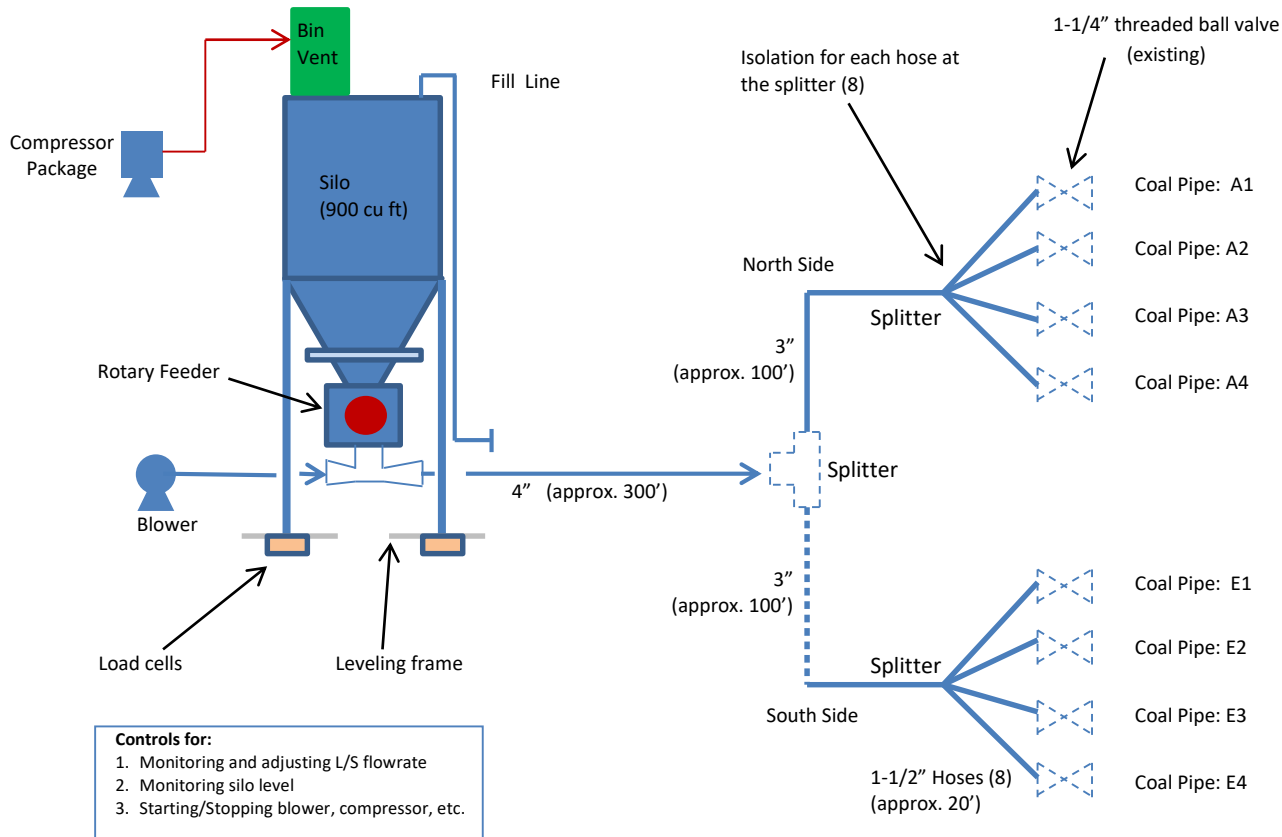

# Arsenic Control Through Limestone Addition:



# Test Plan- Summer 18



3 Week test Plan

## Crist 7 Limestone on coal belt Test Matrix

Week	Date	Time of day (AM/PM)	Test Condition	Target(s)	Load (MW)	Limestone addition		Gas Measurements								Solids Samples		
						Added to coal belt		Pre-SCR				Post-ESP		Post-SCR		Unit 7		
						Flow (ton/hr) (Hz)	Flowrate (%)	Trap A: (As, Se) vapor * Iso-kinetic sampling	Trap B: (HCl)	Trap C: Hg (speciated)	Trap D: SO3 (Week 1 only)	Trap A: (As, Se) vapor * Iso-kinetic sampling	Trap B (HCl)	Trap C: Hg (speciated)	Trap D: SO3 (Week 1 only)	Coal analysis	*ESP Ash (CaO, Cl, Se concentrations)	TCLP (ESP ash)
Evaluation of the effectiveness of limestone addition to the coal in order to decrease the concentration of gaseous arsenic going into the SCR.																		
1	7/10/2018	AM	Test condition #1	As <sub>2</sub> O <sub>3</sub> (gas), HCl	519 MW			4 runs (Fgas inlet)				4 runs (1st run fail)	4 runs			1 per day	2 per day (same time from 2 rows of hoppers)	Ag, As, Ba, Cd, Cr, Hg, Pb, Se, Cl, Br, I
	PM						1 run (up duct)											
	7/11/2018	AM	7/12/2018				7.25 (40.0)	0.85%	3 runs			3 runs	3 runs			1 per day	2 per day (same time from 2 rows of hoppers)	
PM																		
2	7/16/2018	AM	Test condition #3	As <sub>2</sub> O <sub>3</sub> (gas), HCl, Se (gas, ash), Hg	520 MW	4.3 (26.5)	0.55%	3 runs				3 runs	3 runs			1 per day	2 per day (same time from 2 rows of hoppers)	
	PM																	
	7/17/2018	AM	Limestone feedrate adjustment	SO <sub>3</sub>	AGC				3 runs					2 runs	3 runs			
	PM																	
	7/18/2018	AM	Test condition #4	As <sub>2</sub> O <sub>3</sub> (gas), HCl, Se (gas, ash), Hg											3 runs			
PM																		
7/19/2018	AM	Limestone feedrate adjustment	SO <sub>3</sub>	AGC														
PM																		
7/20/2018	AM	Test condition #5	As <sub>2</sub> O <sub>3</sub> (gas), HCl, Se (gas, ash), Hg	AGC														
PM																		
3	7/31/2018	AM	Test Condition #4	"	AGC	5.5 (32)	0.65%	3 runs				3 runs	3 runs			1 per day	2 per day (same time from 2 rows of hoppers)	
	PM																	
	8/2/2018	AM	Test Condition #5	"	AGC	10.6 (60)	1.25%	3 runs				3 runs	3 runs			1 per day	2 per day (same time from 2 rows of hoppers)	Ag, As, Ba, Cd, Cr, Hg, Pb, Se, Cl, Br, I
PM																		

Limestone flowrates of 0, 0.65%, 0.85%, and 1.25% by wt.

As, Se, Hg, SO3, HCl traps tested at 3 different locations.

- Boiler tube leak, inconsistent limestone supply, and coal bunker to boiler lead time were challenges for this test.

# Arsenic Control Through Limestone Addition- Temporary System:

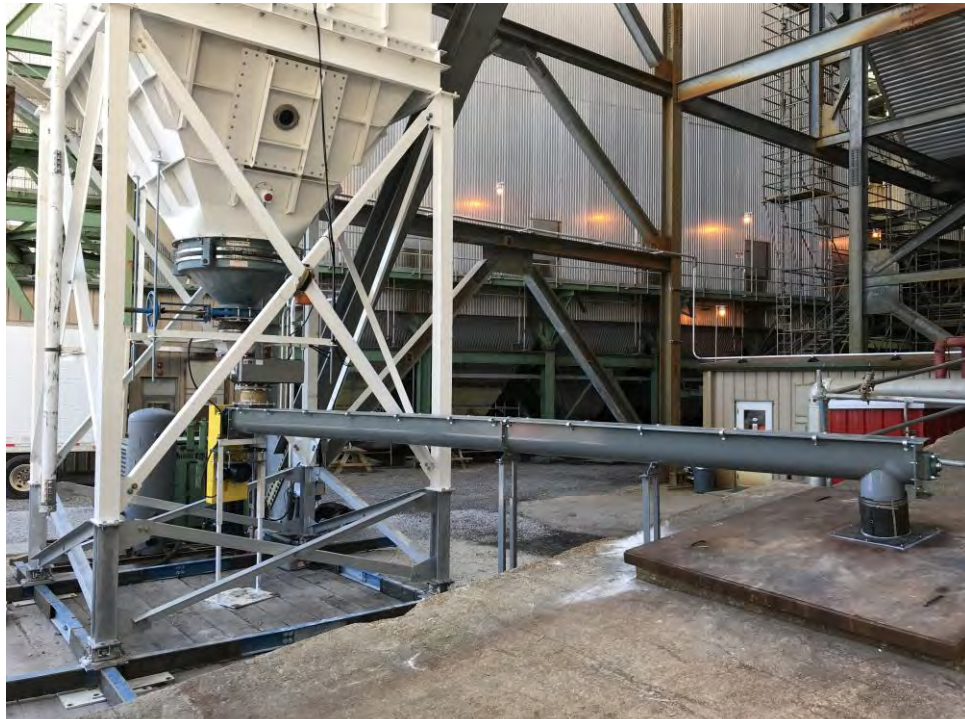

# Coal bunker flow issues: Mass flow vs. Funnel flow

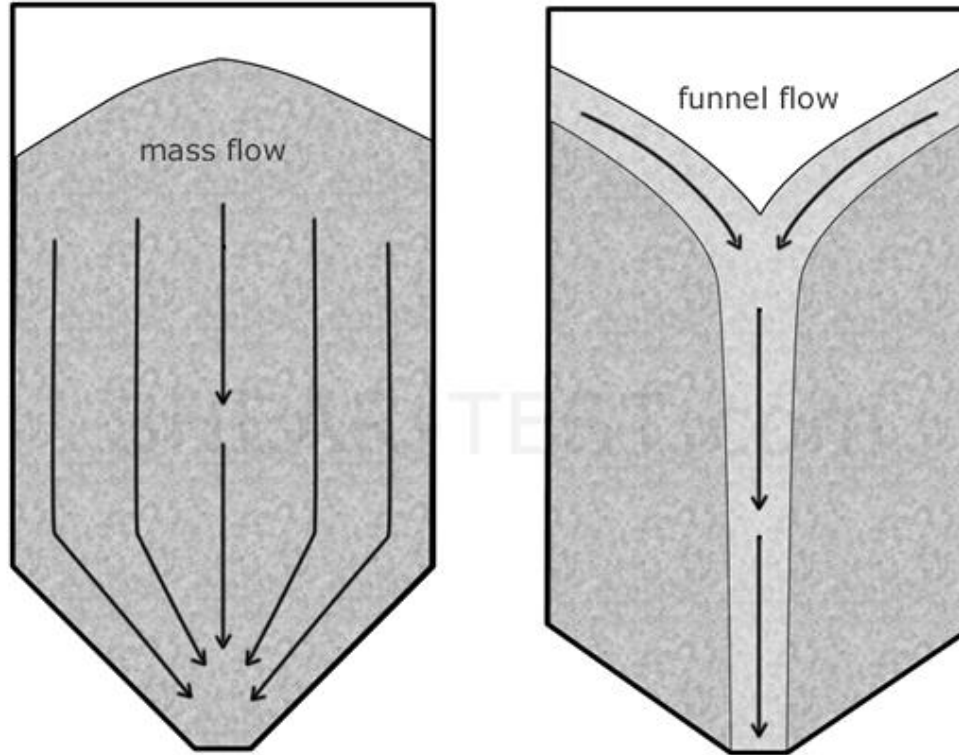

# Sampling Locations



Test port locations attempted to get a representative sample:

- Fgas: Multi-point inlet & outlet sampling
- Upduct: SCR inlet-single point

4.10 FLUE GAS ANALYSIS SYSTEM (FGAS) SCHEMATIC – FIGURE 10

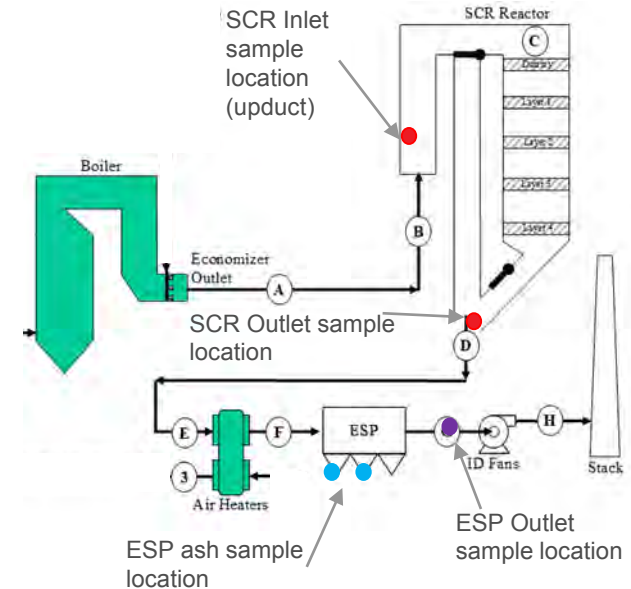
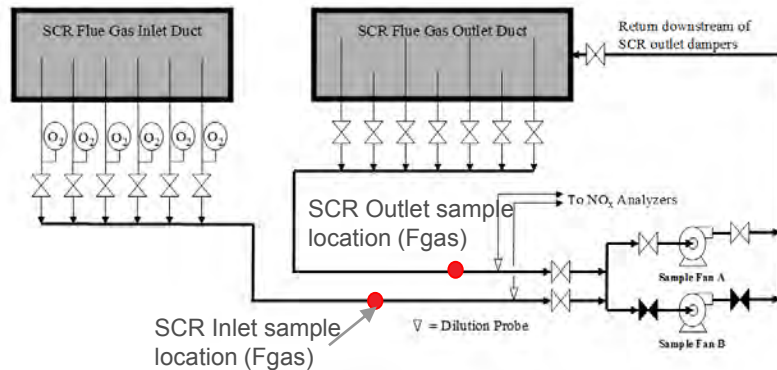

# Spring testing: Comparison of M29 to As trap



Trap

M29

Inlet

Outlet



# Test Results

- **Arsenic vs. limestone measurements (Spring/ Summer 18)**
- **Limestone effects on HCl concentrations (Summer 18)**
- **Fly ash calcium vs. arsenic concentration (Summer 18)**
- **Catalyst activity results + XRF analysis**

# Arsenic vs. limestone measurements (Spring/ Summer 18)



## Gaseous Arsenic vs. Limestone addition

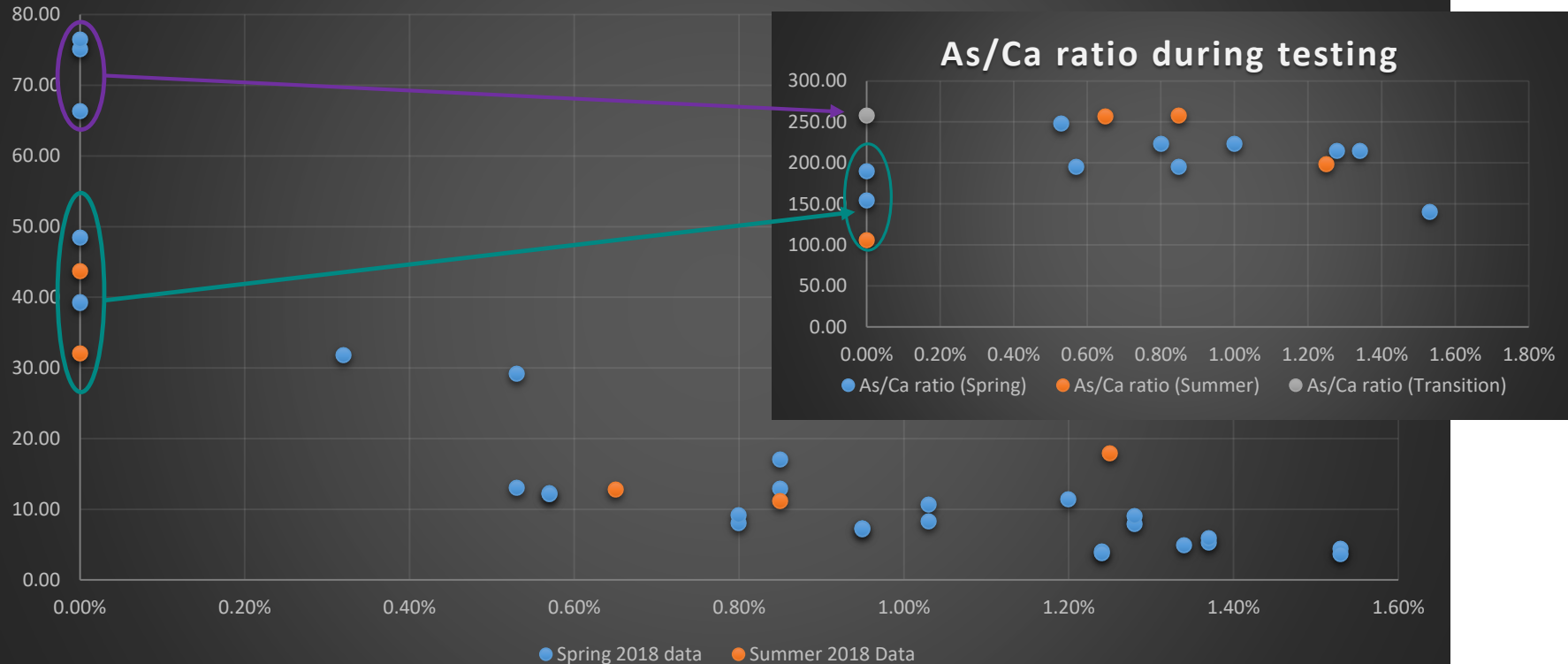

# Limestone effects on HCl concentrations (Summer 18)

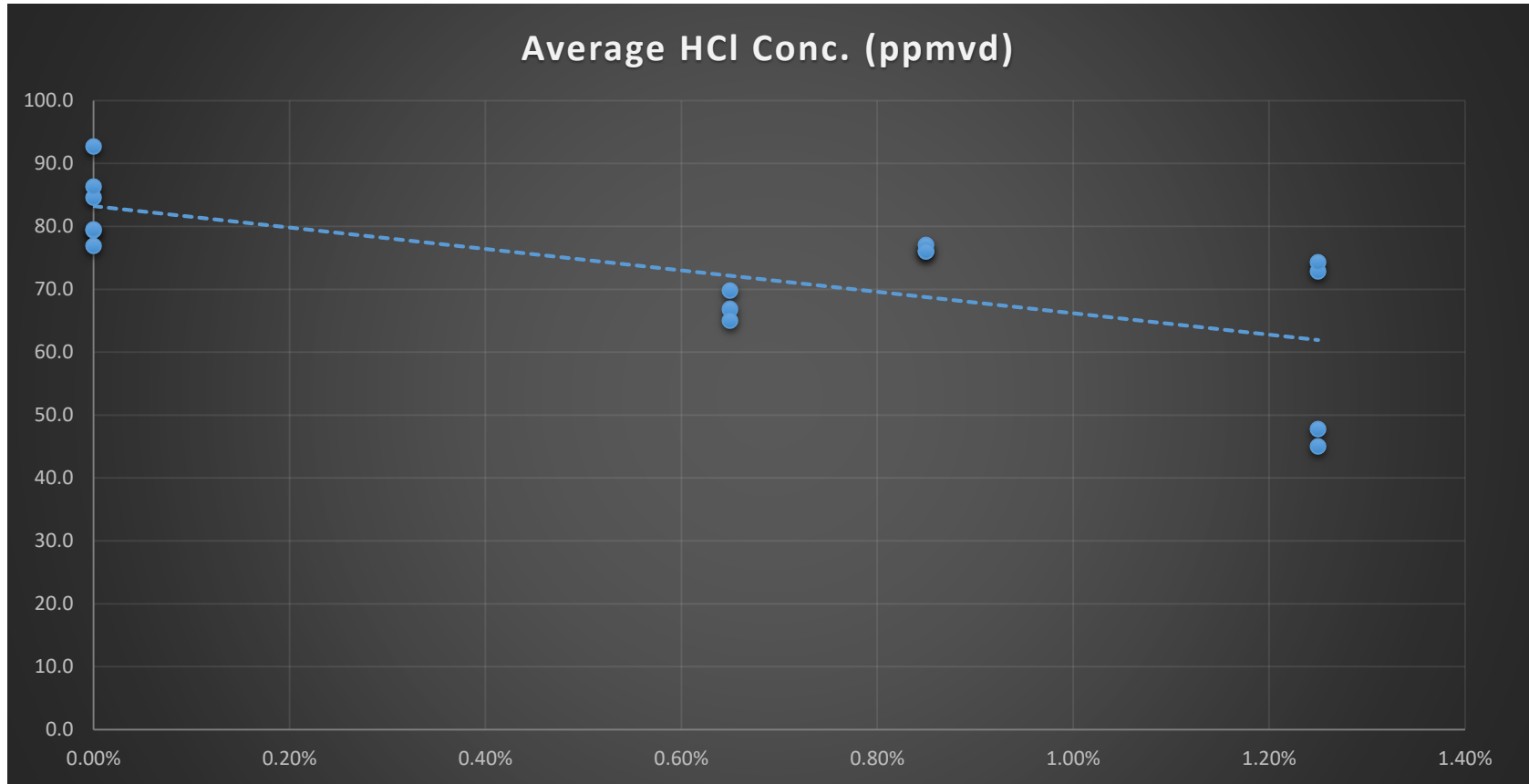

# Fly ash calcium vs. arsenic concentration (Summer 18)

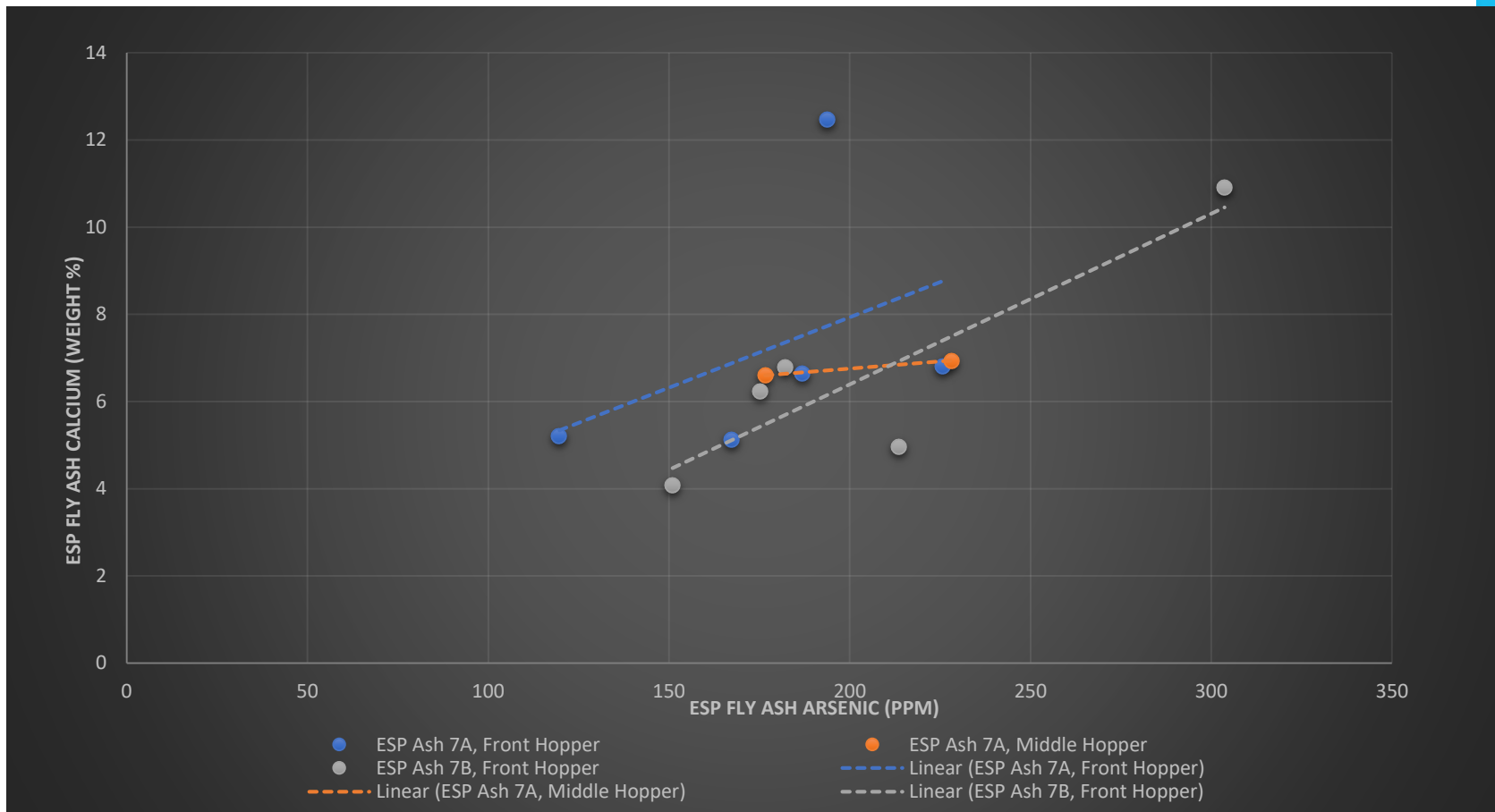

How did the Unit 7 catalyst deactivation rate change after limestone addition?

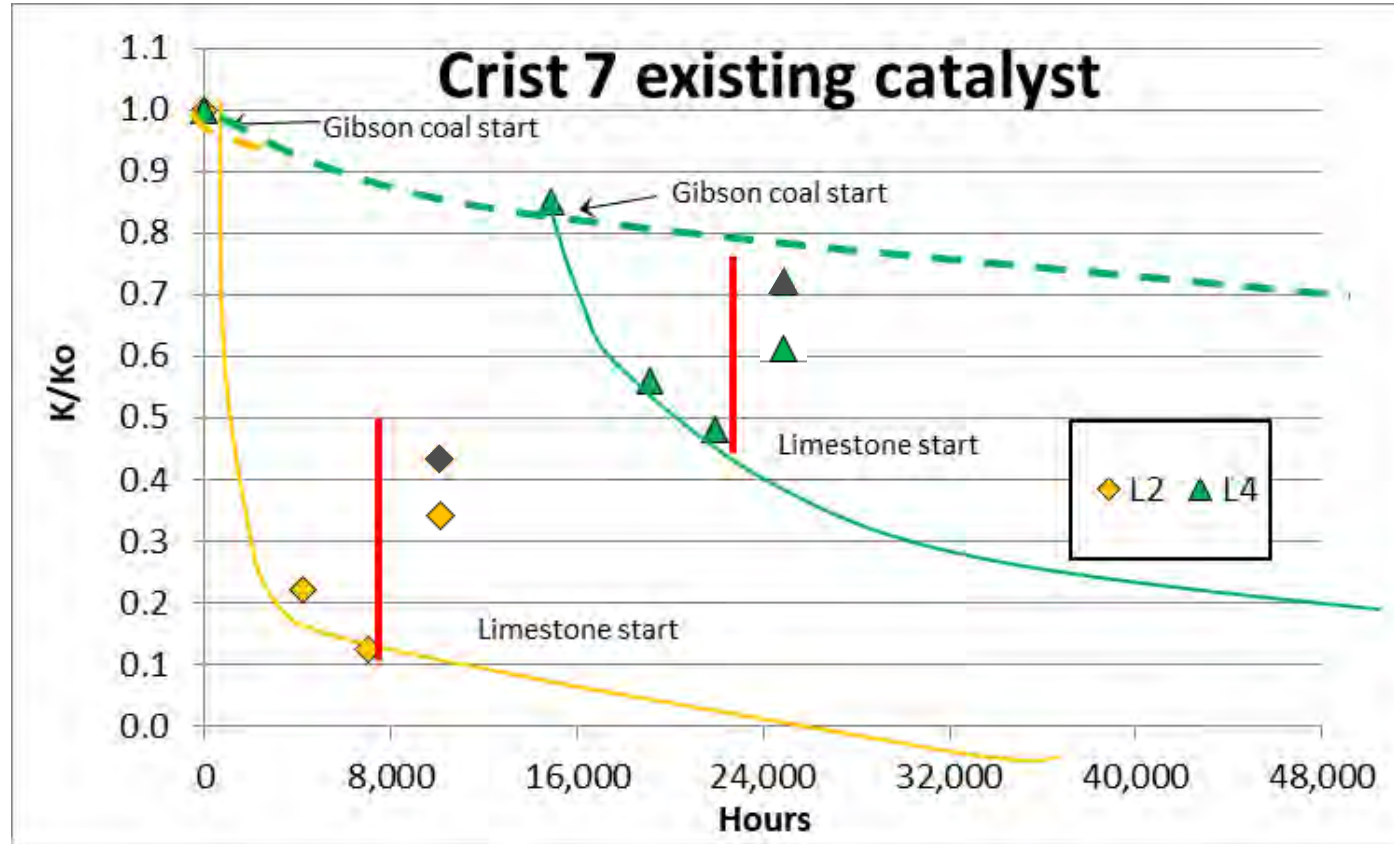

- ◆ Lab 1 test data
- ▲ Lab 2 test data
- ◆ Lab 2 test data
- ▲ Lab 2 test data
- Beginning of limestone mitigation.

# How did the new Unit 7 catalyst deactivate with limestone compared to without?



<u>XRF Analysis</u>	Catalyst Hours	As (ppm) Surface	As (ppm) Bulk	K/K0
Top Layer L2 (no limestone)	4,789	28,050	34,751	0.22
L1 (limestone)	3,000	13,250	10,150	0.76
L3 (limestone)	3,000	8,150	7,263	0.75

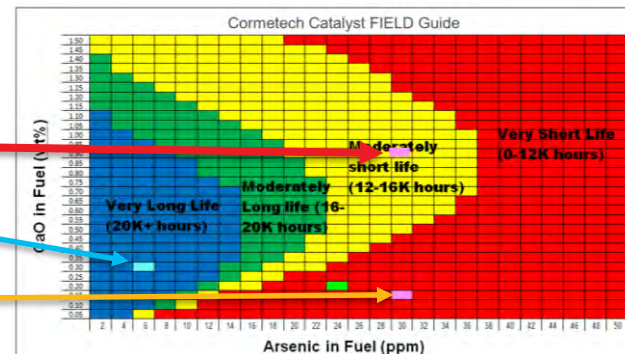
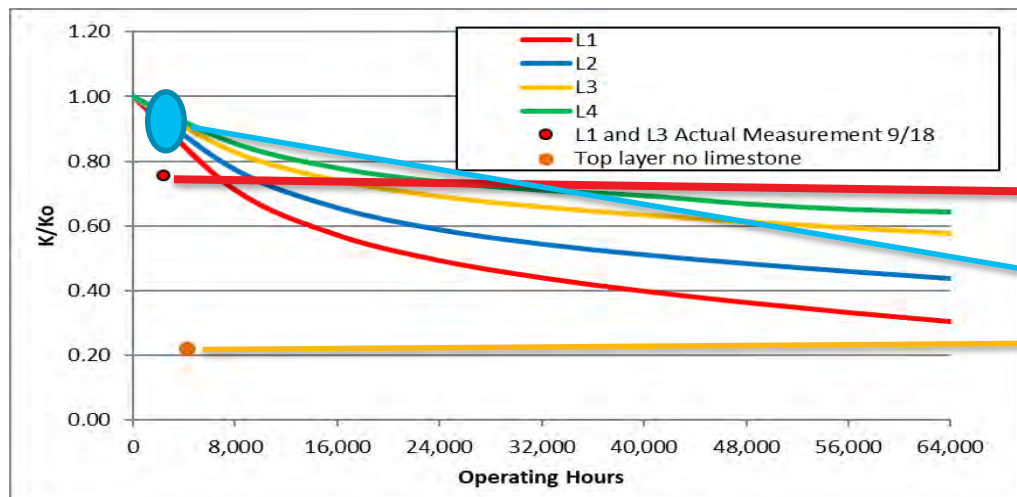

# The new Unit 7 CMP with Limestone addition.

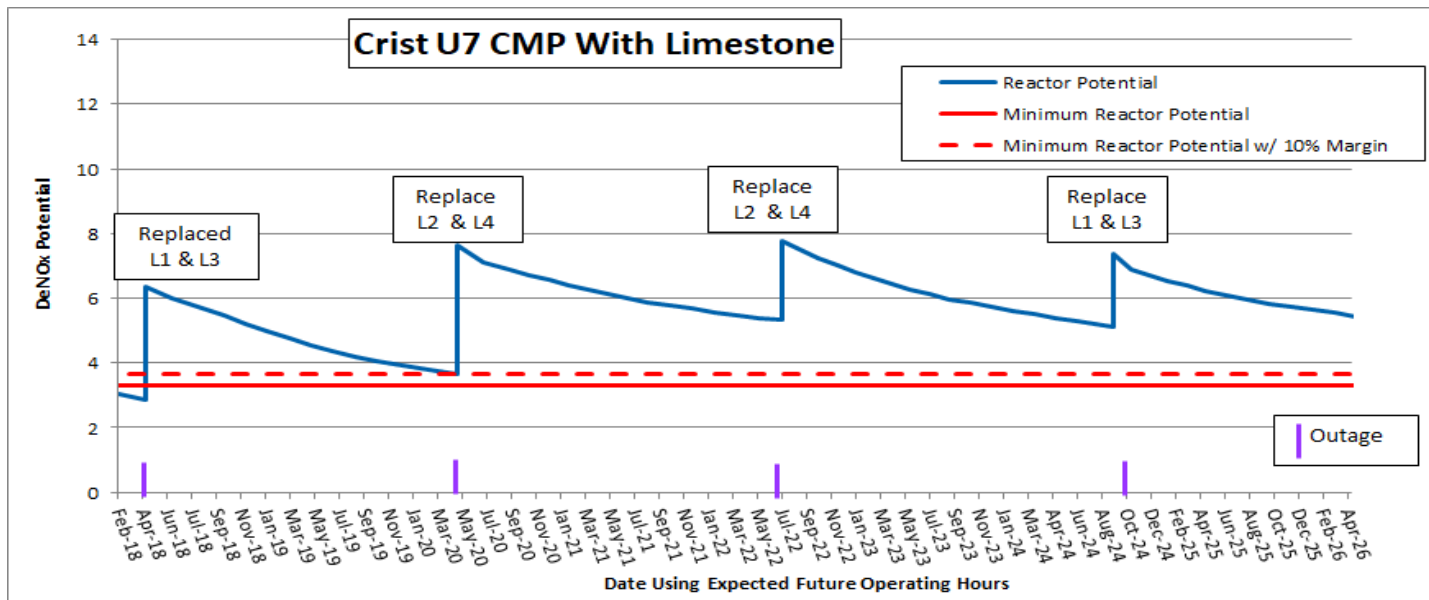

- The updated CMP with Limestone shows 2 layers of catalyst will be needed per 2 year outage cycle.
- More data points are needed to confirm the accuracy of this new CMP.

Unit 6 & Unit 7 both saw a decrease in As concentration through XRF testing with some increase in activity.



Unit/ Layer	Age	Surface As reduction	Bulk As reduction	Delta K	Activity (k) increase
6-3	31,000	18%	9%	-3.7	-10%
6-4	17,000	5%	38%	2.2	6%
7-2	10,000	6%	11%	2.2	5%
7-4	25,000	21%	21%	3.0	10%

- 3 of the 4 catalyst layers from 2 different units showed an over increase in activity 3,500 operating hours after limestone injection began.
- All 4 layers of catalyst showed a decrease in both surface and bulk Arsenic concentrations.

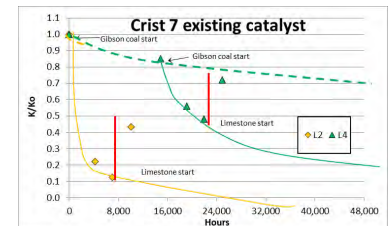

# Conclusions



- Limestone addition is an effective way to mitigate arsenic in the flue gas prior to the SCR. Reduction above 80% is easily achievable.
- There was no change in removal rate if the Limestone was turned on 10 minutes prior to testing, or if the limestone was turned on 8 hours before testing. (Spring Testing)
- The coal bunker flow profiles add more variability to the test results. (Summer)
- We saw no trend or change in Selenium concentrations at different limestone flowrates.
- More data points are needed to determine if limestone can reverse the effects of arsenic poisoning, and to better understand the new deactivation curve with limestone addition.

